



# FOLD! 240 touch

## Style Meets Functionality in a Whole New Dimension

Prepare to be captivated as the **FOLD! 240 touch** defies gravity with its sleek design! Seamlessly gliding forward like a robotic marvel, this ultra-slim 23.8 inch touch monitor transforms effortlessly into a sophisticated tablet, poised elegantly above any surface.

Boasting a responsive touch display, it doubles as a versatile tablet, offering ergonomic comfort and adjustable viewing angles for an unparalleled experience. And for those who prefer a classic display, fear not - a touch-overlay-free version is also available upon request.

## Experience True Tablet Versatility and Beyond - With Just a Touch

Witness as the **FOLD! 240 touch** assumes its rightful place on the table, silently commanding attention. But make no mistake - it's not just a standalone device. Crafted to integrate seamlessly into professional AV setups, it comes equipped with advanced security features, versatile video interfaces, and a host of functionalities essential for any meeting or conference room.

**ELEMENT ONE  
Multimedia GmbH**  
Zum Murgdamm 5  
76456 Kuppenheim  
Germany

Fon: +49 (0) 7222 966 54 20  
Mail: [info@element-one.de](mailto:info@element-one.de)  
[www.element-one.de](http://www.element-one.de)



### The vision of a breathtaking motion

With its expansive 23.8" display, the **FOLD! 240 touch** offers a generous viewing area, ensuring unparalleled comfort and immersion.

*"The vision was to transcend boundaries and create a masterpiece that embodies the best of every world."*

### Features

- 17 mm slim monitor housing made of silver anodized aluminum
- 2 mm hardened & anti-reflective screen
- Compact housing dimensions
- LightWeight-, LowNoise- & LowEnergy-Design
- HDMI HDCP compatible
- FullHD resolution
- 5 years limited warranty
- 2x improved stepper motors 12V & most precise, smooth mechanics
- Electronic clamping protection plus mechanical protection in case of incorrect operation
- Manual lifting function „DirectAxleAccess“ for service, maintenance & installation



## TECHNICAL DATA

# Product Specification



<b>Art.No.</b>	200-240-T IP FOLD TOUCH	<b>Monitor Size:</b>	23.8" (16:9)
<b>Type</b>	FOLD! 240 TOUCH	<b>Resolution:</b>	1,920 x 1,080 - FullHD, 16.7M colors (6bit + A-FRC)
<b>Function</b>	Vertically retractable monitor; furniture integratable 23.8" touch monitor system with electromechanical drive / lifting system of integrated 17 mm slimline aluminum display; automatic display tilt 0° - 60°; inverse, vertical movement; Control via push-button on the device or via remote control interfaces (TCP / IP or contact); Manual lifting via DirectAxleAccess for service, maintenance, installation purposes. Low noise <40dB; two 12 V stepper motors with precise synchronization - for simultaneous operation when using multiple monitors; independent electromotive adjustment of the inclination angle - both central presetting via remote interface as well as individual adjustment by user.	<b>Brightness:</b>	250 cd/m2
<b>Material</b>	Monitor: Milled aluminum, powder coated Color RAL 9006 white aluminum - metallic fine structure - matt, 2 mm anti reflective protective screen, black   Mechanics: Anodized aluminum & stainless steel; mounting frame and closure flap: stainless, brushed	<b>Contrast ratio:</b>	(typ.) 1,000:1
		<b>Viewing angle:</b>	Horizontal 178° / vertical 178°
		<b>Viewing area:</b>	527.04( H) x 296.46( V) mm
		<b>Pixel Pitch:</b>	0.2745 x 0.2745 mm
		<b>LED life time:</b>	up to 30,000 hours
		<b>Mass:</b>	~19.5 kg
		<b>Dimensions:</b>	660 x 120 x 586 mm (LxWxD)
		<b>Power consumption:</b>	typ. 20 Watt
		<b>P. consumption Monitor:</b>	OFF: 0.12 Watt, Sleep: 0.60 Watts, ON: 18.4 Watt
		<b>Inclination angle:</b>	0° - 60° inclination
		<b>Height Monitor elevated:</b>	418 mm at 0° inclination / 250 mm at 60° inclination
		<b>2x stepper motor:</b>	Display motion & Tilt function
		<b>Video interface:</b>	HDMI, (optional: Displayport, DVI); HDCP compliant
		<b>Touchscreen interface:</b>	USB
		<b>Remote control:</b>	9-pin d-sub serial + RJ45 TCP/IP for device operation - and adjustment of motion parameter & firmware update (E1 connection cable & software required)
		<b>Scope of supply:</b>	Scope of supply: Desktop Power Supply - Input: 100-240V AC, 50 / 60Hz. 1.5A; Output: 12V 60W MAX 5.A (Cable length DC ~ 140cm) Power cord 1.5m / Underbench clamp Bracket CONVERS-2 Universal / 1 pair

0° inclination

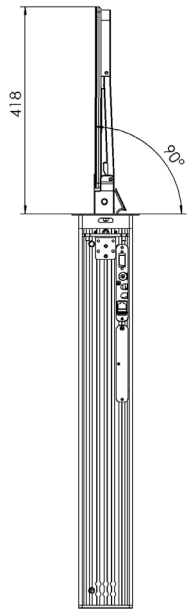

60° max. inclination

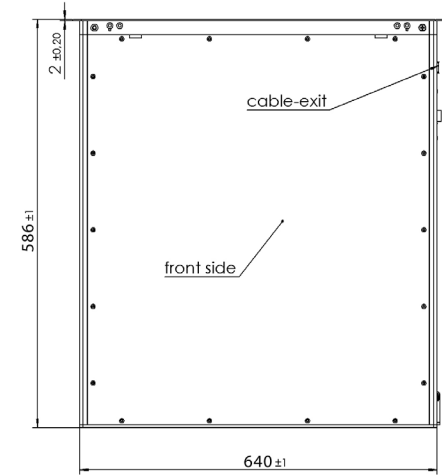
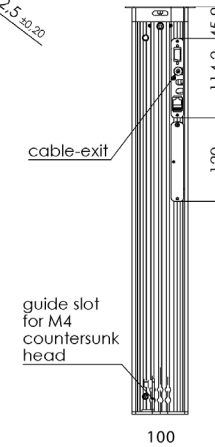
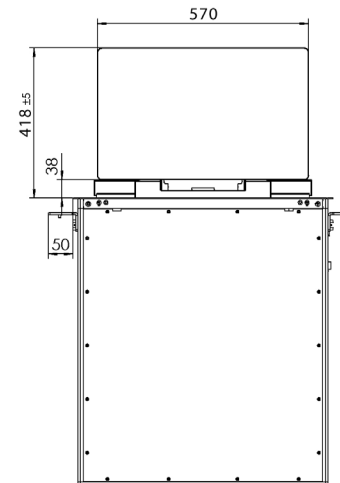
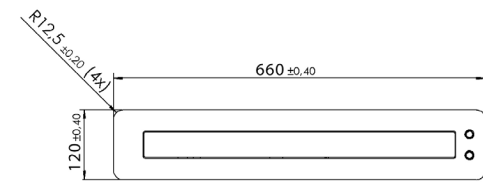
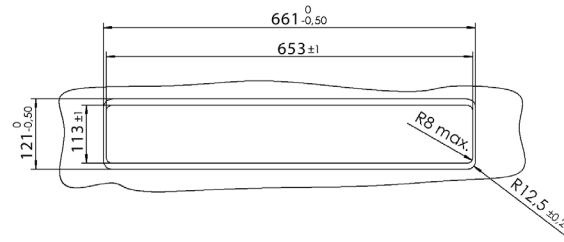
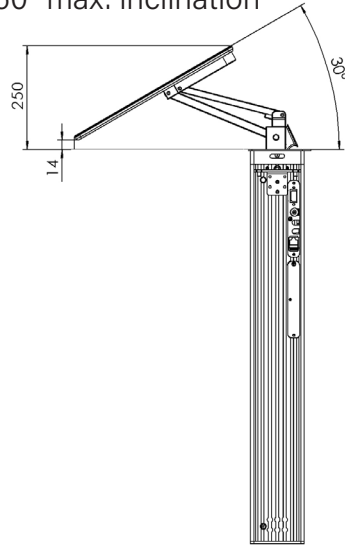

changings and errors excepted

# Dimensions



**ELEMENT ONE**  
Multimedia GmbH  
Zum Murgdamm 5  
76456 Kuppenheim  
Germany  
Fon: +49 (0) 7222 966 54 20  
Mail: [info@element-one.de](mailto:info@element-one.de)  
[www.element-one.de](http://www.element-one.de)